

	TECHNICAL SPECIFICATION	
--	--------------------------------	--

TECHNICAL SPECIFICATION FOR INSULATION PIERCING CONNECTORS, ANCHOR (DEAD END) & SUSPENSION ACCESSORIES & OTHER ACCESSORIES FOR AERIAL BUNCHED CABLES FOR WORKING VOLTAGE UPTO AND INCLUDING 1100 VOLTS

1.0 SCOPE

This specification covers the design, manufacture, assembly, testing and supply of Accessories for anchoring, suspending & making connections to Aerial Bunched Cables rated 1100 volts and insulated with cross-linked polyethylene.

2.0 STANDARD

The design, performance and test requirements shall conform to this specification and the following standards. However in case of any conflict, the requirements of this specification shall prevail.

λ	NFC 33-020	Insulation Piercing Connectors
λ	NFC 33-209	LV Aerial Bunched Cables
λ	NFC 20-540	Environment Testing for Outdoor
λ	NFC 33-004	Electrical Ageing Test
λ	NFC 33-040	Suspension Equipments
λ	NFC 33-041	Anchoring Devices
λ	IS 14255	LV Aerial Bunched Cables

The Devices shall also be compatible with the cables of sizes & dimensions as defined in the Cable Specifications for the cables with which they are intended to be used.

3.0 CLIMATIC CONDITIONS

For the purpose of designing the climatic conditions as specified in annexure-1 shall be considered.

4.0 CABLE DATA

The standard sizes and characteristics of the phase and street lighting conductors, messenger wires shall be as specified in IS : 14255-1995.

	TECHNICAL SPECIFICATION	
--	--------------------------------	--

The Accessories of LT XLPE Insulated Aerial Bunched Cables (ABC) with insulated messenger cum neutral are specified below :

- a) The ABC accessories should be of proven design with minimum 2 years record of satisfactory operation with a major utility. Order copies and Performance Certificates should be enclosed with the offer.
- b) Since ABC accessories are to be used with insulated neutral-cum-messenger, their design should incorporate specific features to prevent damage to the insulation which meeting the required electrical, mechanical & thermal requirements.
- c) All mechanical, electrical & thermal ratings should meet or exceed 90% of the corresponding ratings of the cable, or the values specified herein, whichever are more stringent.
- d) The accessories should provide “Double Insulation” so that a single point failure of insulation will not result in the system tripping.

5.0 **THE ABC ACCESSORIES**

The ABC Accessories shall consist of the following :

a)	Insulation Piercing Connectors (IPC)	:	For making tap-off/branch connectors/service connector to an ABC line.
b)	Anchoring Assembly (AA)	:	For fitting onto a pole for anchoring the end of a length of ABC, or for a major change in direction.
c)	Suspension Assembly (SA)	:	For supporting a length of ABC at an intermediate pole in a length, with small angle of deviation.
d)	Service clamp (sc)	:	For anchor Insulated service lines (armoured or unarmour)
e)	Transformer Connections	:	For connection to the transformer bushing.
f)	Junction Sleeves	:	For Phases, neutral messengers & Street lighting conductor.
g)	ABC Service Main Distribution Box	:	For Distribution of multiple no. of Service Connections from Main AB cable.

	<h1>TECHNICAL SPECIFICATION</h1>	
--	----------------------------------	--

5.1 **Insulation Piercing Connectors (IPC)**

5.1.1 Insulation Piercing Connectors (IPC) are used for making Tee/Tap-off/Service connectors to an ABC/Bare Overhead Line.

5.1.2 Insulation Piercing Connectors are designed to make a connection between the uncut main conductor and a branch cable conductor without having to strip either cable to expose the conductor instead the tightening action of the IPC will first pierce the Insulation, then make good electrical contact between the main end and branch conductor while simultaneously insulating and sealing the connection.

5.1.3 **Constructional Features of IPC**

5.1.3.1 The housing shall be made entirely of mechanical and weather resistant plastic insulation material and no metallic part outside the housing is acceptable except for the tightening bolt.

5.1.3.2 Any metallic part that is exposed must not be capable of carrying a potential during or after connector installation.

5.1.3.3 Screws or nuts assigned for fitting with IPC (Insulating Piercing connector), must be fitted with torque limiting shear heads to prevent over tightening or under tightening (min & max torque values to be specified by Manufacturer).

5.1.3.4 The IPC must perform piercing and connection on Main and Branch cable simultaneously.

5.1.3.5 The IPCs shall be water proof and the water tightness shall be ensured by appropriate elastomer materials and not by grease, gel or paste alone.

5.1.3.6 Design of IPC should be such as to not cause damage to insulation of adjacent conductors due to vibration and relative movement during service.

5.1.3.7 The connector shall have a rigid removable end cap which can be slide fitted onto the main connector body on either right or left by the installer (depending on site requirement) for sealing the cut end of the branch cable. Once the connector is fitted, it should not be possible to remove the cap without removing the connector.

	<h2>TECHNICAL SPECIFICATION</h2>	
--	----------------------------------	--

5.1.3.8 All the metallic parts of the connector should be corrosion resistant and there should not be any appreciable change in contact resistance & temperature after overloads & load cycling.

- λ The contact plates should be made of tinned copper.
- λ Connector teeth should be factory greased & sealed to retard water or moisture ingress & corrosion.
- λ The Insulation material should be made of weather & UV resistant reinforced polymer.
- λ The outer metallic part should have potential free tightening bolts to allow safe installation on live lines.

5.1.4 Mechanical Tightening and Electrical Continuity

5.1.4.1 Connectors shall be tightened upto 70% of the minimum torque indicated by the Manufacturer. At this torque electrical contact should have occurred between conductors to be joined. Then connectors shall be tightened up to the breakdown of the shear heads and lastly, upto 1.5 times the maxm. torque indicated by the manufacturer.

For the connector fitted with two screws on the same core, after the breakdown of the shear heads tightening may be carried out manually and alternatively using a torque meter. The test conditions shall be as close as possible to those defined for the use of the test machine as per NF-C standard.

5.1.4.2 At 1.5 times the maximum torque indicated by the manufacturer, there shall be no breakdown of any part of the connector or the core conductor.

5.1.4.3 Maximum rated torque shall not exceed 20 N.m for conductor <95 sq.mm and 30 for >95 but <150 sq.mm.

5.1.4.4 Tightening screws shall have hex. Heads of 10 mm, 13 mm or 17 mm only.

5.1.5 Effect of Tightening on Main Core of IPC

TECHNICAL SPECIFICATION

5.1.5.1 The connector shall be fitted approx. at the center of the main core, which is secure between two anchoring points 0.5 mtr. To 1.5 mtr. apart. At the time of fitting the connectors, the main core shall be under longitudinal tension at 20% of the load indicated in Table-1 :

Table - 1	
Nominal Cross – section (sq.mm.)	Tensile Strength (Newton)
16	1200
25	1800
35	2500
50	3500
70	5000
150	10000

5.1.5.2 Tensile strain shall be increased to the full value indicated in the Table 1 and held minute. There should be no breakdown of the core conductor.

5.1.6 Effect of Tightening on Branch Core of IPC

5.1.6.1 Test specimen shall be made up as in clause 5.1.5.1 except that this shall be do the smallest cross sections of main and branch conductors within its range.

5.1.6.2 An increasing tensile load shall be applied to the Branch Conductor along the axis of the recess for the Branch cable. Load shall increase at 100 – 500 N/minute until it reaches the value specified in the Table 2 and maintained for 1 minute.

Table - 2	
Nominal Cross – section (sq.mm.)	Tensile Strength (Newton)
16 (Alu)	290
25	450
35 & above	500

5.1.6.3 No slippage or breaking of conductor shall occur.

5.1.7 Dielectric & Water Tightness Test of IPC

5.1.7.1 The connector is tightened up to the minimum torque indicated by the manufacturer.

TECHNICAL SPECIFICATION

5.1.7.2 Connectors are mounted on

λ Minimum cross section of main core.

λ Maximum cross section of main core.

5.1.7.3 In each case Branch is of minimum cross section.

5.1.7.4 Protection caps for the branch cable are to be used in accordance with the requirements of clause 5.1.3.7. An additional water tight cap of any design may be used to seal one end of the main cable if it is immersed under water. No additional gel or any protection is to be provided while installing connector.

5.1.7.5 The entire assembly shall be immersed at a depth of approx. 30 cms. For 30 minutes with the free ends of main and branch cable out of the water.

5.1.7.6 An AC voltage of 6 kV shall be applied between the water bath and each of the cores in turn for 1 minute. There shall be no flashover or electrical tripping with a trip setting of 10 mA \pm 0.5mA.

5.1.8 Electrical & Ageing Test of IPC

5.1.8.1 Two test configurations are used according to Table 3 with the connections tightened to the minimum torque specified by their manufacturers and resistance recorded.

Configuration	Main core cross section	Branch core cross section Tensile Strength (K.N)
1 st Configuration	Maximum	Maximum
2 nd Configuration	Maximum	Maximum

5.1.8.2 The configurations are subjected to 200 heat cycles by injecting suitable current into them. In each cycle the temperature of the conductor shall be raised from ambient to 120 \pm 5°C as, measured by a thermocouple.

TECHNICAL SPECIFICATION

- 5.1.8.3 The duration of each heating cycle is chosen to maintain a sufficiently steady temperature of $120 \pm 5^{\circ}\text{C}$ for 15 minutes. The duration of each cooling cycle is chosen to bring the conductor temperature to within 2°C of ambient.
- 5.1.8.4 Nominal heating current is indicated in the Table-4. It shall be permissible to accelerate the temperature rise by using a current up to 1.5 times the nominal current and to accelerate the cooling period by use of a fan or air blower.

Nominal Cross – section (sq. mm.)	Nominal Heating Current (A)
16	102
25	139
35	175
50	225
70	283
95	350
120	412
150	480
185	545
240	670

- 5.1.8.5 The over current test of Clause 5.1.9 shall be done after 50 cycles if the connector is a safety connector designed to ground a phase connector while the line is being worked on.
- 5.1.8.6 At the end of the 200 cycles the resistance shall again be measured. It shall not differ from the initial value by more than 12%.
- 5.1.9 Over Current Test of IPC
- 5.1.9.1 Over current test is required to establish the performance of Safety Connectors that are intended to provide a safe path to ground for the phases while the line is de-energised for working. It establishes the performance of the connector under short term over load conditions.

	<h2>TECHNICAL SPECIFICATION</h2>	
--	----------------------------------	--

5.1.9.2 After the first 50 cycles of clause 5.1.8, the connectors are subjected to 4 over currents of 1 sec duration each.

5.1.9.3 The conductor temperature at the start of the over current test should be not more than 35°C.

5.1.9.4 Current density during over current shall be 100 A/sq.mm for Aluminium and 95 A/sq.mm for Aluminium – Alloy Conductor.

5.1.9.5 Variation in time of over current is permissible between 0.85 sec & 1.15 sec., provided it maintains the relationship $I^2t = K$ where,

I = rms value of over current in Amps.

t = time in seconds

K = Constant

5.1.9.6 After the over current test the electrical ageing test of clause 5.1.8 shall be resumed.

5.1.10 Type Test of IPC

5.1.10.1 Type Test Reports should be submitted from an Independent Laboratory of Repute or the Works Laboratory in case of a foreign manufacturer covering the following (on any convenient size of fitting of same design made from the same materials).

5.1.10.2 The installation of the connectors shall be done by the laboratory following instructions provided by the manufacturer.

5.1.10.3 The Test report shall record the embossing and marking on the connector.

5.1.10.4 The following shall constitute Type Tests for IPC :

- λ Electrical Ageing Test
- λ Dielectric and Water Tightness Test.
- λ Mechanical Tightening Test
- λ Effect of Tightening on main Core
- λ Effect of Tightening on Branch core

	<h1>TECHNICAL SPECIFICATION</h1>	
--	----------------------------------	--

- λ Over-current Test (if applicable)

The following shall be Type Test for Suspension Assembly (SA)

- λ Mechanical Test
- λ Voltage Test
- λ Climatic Aging Test
- λ Corrosion Test
- λ Endurance Test under Thermal & Mechanical Stresses

The following shall be Type Tests for Anchoring Assemblies (AA)

- λ Mechanical Test
- λ Voltage Test
- λ Dynamic Test
- λ Climatic Aging Test
- λ Corrosion Test
- λ Endurance Test under Thermal & Mechanical Stresses

5.2 Anchoring Clamp for Insulated Messenger :

The clamps should be designed to Anchor LT-AB cable with insulated messenger. The clamp should consists of an Aluminium alloy corrosion resistant castled body, bail of stainless steel and self adjusting plastic wedges which shall anchor/hold the neutral messenger without damaging the insulation.

- λ No losable part in the process of clamping arrangement
- λ The clamp should conform to the standard NFC 33041 and 33042 or equivalent I.S. if any.
- λ The clamp body should be made of corrosion resistant Alluminium alloy, bail should be of stainless steel and wedges should be weather and UV resistant polymer.
- λ Ultimate tensile strength of the clamp should not be less than 15 km for 50/70 sq.mm insulated messenger wire / 10 KN for 25/35 sq.mm insulated messenger wire.

	TECHNICAL SPECIFICATION	
--	--------------------------------	--

λ Slip load of the clamp should not be less than 3 KN for 50/70 sq.mm. messenger wire / 2 KN for 25/35 sq.mm. messenger wire.

5.2.1 Anchoring assemblies are used to firmly attach the messenger of ABC to a support and transmit the mechanical tension.

λ at the end of a run or to the supporting structures

λ at a major change in direction.

5.2.2 Each Anchoring Assembly shall include.

λ One number tension bracket.

λ One number wedge type tension clamp

λ Flexible Rope for fixing tension clamp to bracket.

5.2.3 Anchoring assemblies shall be supplied in sets to ensure compatibility of the materials against corrosion or wear of moving parts.

5.2.1 Tension Bracket of AA

5.2.4.1 The tension bracket shall be made out of a single piece of Aluminium alloy suitable for attachment to a pole either by

a) 16mm galvanized steel bolt (s) or

b) two stainless Steel straps of 20 x 0.7 mm.

5.2.4.2 The tension bracket should be designed to ensure the Flexible rope cannot slip out at any angle.

5.2.4.3 The tension bracket should be rated and tested for the loads specified in Table-5. The load shall be applied at an angle of 45⁰ from the normal to the surface of mounting of the bracket.

Table - 5			
Conductor Size (Sq.mm.)	Rating	Load for deformation <10mm (Newtons)	Load for deformation <30mm & no-break (Newtons)
25-35	1500 Kg.	12,000	15,000

	TECHNICAL SPECIFICATION	
--	--------------------------------	--

50-95	2000 Kg.	15,600	19,500
-------	----------	--------	--------

5.2.5 Flexible Rope of AA

5.2.5.1 The Anchoring assembly shall be supplied with a stainless steel flexible Rope to connect the Tension Clamp to the Tension Bracket.

5.2.5.2 The rope should have sufficient flexibility to ease the torsional movement of the ABC System.

5.2.5.3 The Rope should be pre-fitted with compression type end fittings to secure the tension clamp.

5.2.5.4 A wear resistant moveable saddle should be un-loosably fitted on the Rope to prevent abrasion at the point of fitting into the tension bracket.

5.2.5.5. The Rope should have sufficient mechanical strength to withstand the mechanical test for the complete assembly tests in this specification.

5.2.6 Wedge Type Tension Clamp of AA

5.2.6.1 Wedge type clamps shall be used for clamping the messenger without damaging the insulation.

5.2.6.2 The clamp shall be capable of clamping an uncut messenger so that it can continue without break to the connecting point or next span.

5.2.6.3 The clamp shall be fully insulating type of mechanical and weather resisting thermoplastic.

5.2.6.4 No bolts or loose parts are allowed as part of the Clamping system.

5.2.6.5 No tools shall be needed for fitting the messenger into the clamp.

5.2.6.6 The clamp shall be self tightening and capable of holding without slippage the load specified in the Table-6.

	TECHNICAL SPECIFICATION	
--	--------------------------------	--

Table - 6				
Conductor Size		Rating (Kg.)	T start (I minute) (Newtons)	T final (I minute) (Newtons)
Sq. mm.	Dia. (mm)			
25-35	8-11	1000 Kg.	8,000	10,000
50-54	12-14	1500 Kg.	12,000	15,000
70-95	13.5-16	2000 Kg.	12,000	15,000

5.2.6.7 After fitting the insulated messenger in the clamp, load T start will be held for 1 minute & then load increased to T final at rate between 5000 – 7,500 N/mtr. In each case there shall be no breakdown of any part of clamp and slippage of messenger in relation to the clamp.

5.2.7 Voltage Test on Clamp of AA

5.2.7.1 Voltage test is carried out on anchor clamps to ensure no damage is caused to the insulated messenger.

5.2.7.2 A conductive rod of dia. corresponding to the average dia. that can be accommodated in the clamp is fitted into the clamp, protruding by approx. 50mm at each end of the tightening piece.

5.2.7.3 The rod and clamp is subjected to tensile load as stated in Table 7 below when fixed to a support in its normal manner.

Table - 7			
Conductor Size		Normal rating (kg)	Load Applied (N)
Sq. mm.	Dia. (mm)		
25-35	8-11	1000	2000
50-54	12-14	1500	4000
70-95	13.5-16	2000	4000

	TECHNICAL SPECIFICATION	
--	--------------------------------	--

5.2.7.4 A power frequency voltage of 6 kV is applied for 1 minute between the rod and conductive part of the clamp, or fixation point in absence of conductive part.

5.2.7.5 No breakdown or flashover shall occur. There shall be no tripping due to leakage with a setting of 10 ± 0.5 mA.

5.2.8 Endurance under Mechanical & Thermal Stress of AA

5.2.8.1 This test is done on clamp rated 1500 Kg. or 2000 Kg. using insulated messenger 50 to 70 sq. mm.

5.2.8.2 A neutral messenger is fitted between two anchor clamps, with clamp spacing approx. 5 mtr. & 1 mtr. Of messenger protruding from the end. Marks are made to enable measurement of slippage.

5.2.8.3 The sample is subjected to 500 cycles of 90 minutes each as described below :

5.2.8.3.1 Messenger temperature is raised by passing an AC current to $60 + 3^{\circ}\text{C}$ within 15 minutes. This temperature is maintained for at least 30 minutes to give a total heating period of 45 mts. Per cycle.

5.2.8.3.2 Messenger is allowed to cool naturally to ambient for further 45 minutes to complete 90mts. Cycle time.

5.2.8.3.3 Mechanical load is applied during the cycle as per table 8 below. Load F1 is applied throughout the cycle, except for a short period of 5 sec. to 60 sec. when it is gradually increased from F1 to F2 at any time during the last 15 minutes of the 90 minute cycle.

Table - 8				
Conductor Size		Rating (Kg.)	F1 (Newtons)	F2 (Newtons)
Sq. mm.	Dia. (mm)			
25-35	8-11	1000 Kg.	2,200	5,000
50-54	12-14	1500 Kg.	4,000	7,500
70-95	13.5-16	2000 Kg.	4,500	10,000

	<h2>TECHNICAL SPECIFICATION</h2>	
--	----------------------------------	--

5.2.8.3.4 There should be no slippage greater than 4 mm after 2 cycles or greater than 8 mm after 500 cycles.

5.2.8.3.5 Voltage test is done at the end of the 500 cycles by immersing the test specimen of neutral messenger and clamps in water of resistivity not less than 200 Ohm mtr. For 30 minutes.

5.2.8.3.6 A voltage of 10 kV ac is applied for 1 minute between messenger and water bath using a trip setting of 10 + 0.5 am. There should be no breakdown or tripping.

5.3 **Suspension clamp for insulated neutral messenger:**

The clamp should be designed to hang L.T – AB cable with insulated neutral messengers. The neutral messengers should be fixed by an adjustable grip device. A movable link should allow longitudinal and transversal movement of the clamp body.

- λ No losable part in the process of clamping arrangement.
- λ The clamp should conform to the standard NFC 33040 or equivalent I.S, if any.
- λ The clamp and the link made of Polymer should provide an additional insulation between the cable and the pole.
- λ The clamps and movable links should be made of weather and UV resistant glass fibre reinforced polymer.
- λ Clamps should be fixed with pole by eye hook / bracket. Bracket should be made of corrosion resistant aluminium alloy.
- λ Ultimate tensile strength of the clamp should not be less than 15 KN for 50/70 sq.mm. insulated messenger wire 4.3 KN for 25/35 sq.mm. insulated messenger wire.
- λ Maximum allowable load of the clamp should not be less than 20 KN for 50/70 sq.mm. insulated messenger wire/15 KN for 25/30 sq.mm insulated messenger wire.

	TECHNICAL SPECIFICATION	
--	--------------------------------	--

5.3.1 Suspension Assembly is used for supporting an ABC by installation on the messenger at an intermediate point of support such as a pole. It can accommodate small angles of deviation upto 30°.

5.3.2 Each Suspension Assembly shall consist of :

- λ One number Suspension Bracket.
- λ One number moveable (articulated) connecting link.
- λ One number Suspension Clamp.

5.3.3 Suspension Assemblies shall be supplied in sets to ensure compatibility of the materials against corrosion or wear of rotating/moving parts.

5.3.4 Suspension Bracket of SA

5.3.4.1 The Suspension Bracket shall be made from single piece aluminium alloy suitable for attachment to a pole by either.

- a) 16 mm galvanized steel bolt or
- b) Two stainless steel straps.

5.3.4.2 The Suspension Bracket shall be provided with an upper bulge to prevent the clamp from turning over on the Bracket for more than 45° from the horizontal or to within less than 60 mm from the pole / fixing structure.

5.3.4.3 The Suspension Bracket should be so designed to ensure that the articulated link cannot slip out of it.

5.3.4.4 Suspension Brackets shall be designed to withstand a load applied at the anchoring point of the movable link as per Table – 9 below without deformation of more than 10mm or breakdown at 33° below horizontal (there should be no longitudinal component of load parallel to the plane of fixing).

Table - 9			
Conductor Size		Normal Rating	Load (Newtons)
Sq. mm.	Dia. (mm)		
25-54	8-15	1500 Kg.	12500

	TECHNICAL SPECIFICATION	
--	--------------------------------	--

70-95	13-17	2000 Kg.	14000
-------	-------	----------	-------

5.3.5 Movable (Articulated) Link of SA

5.3.5.1 Movable Links are used between the Suspension Bracket and Suspension Clamp to allow a degree of movement and flexibility between the two.

5.3.5.2 Moveable Links should be made fully of insulating type of mechanical and weather resistant thermoplastic. A metallic wear resistant ring should however be fitted at point of contact between the Suspension Bracket and the movable link.

5.3.5.3 The Movable link should be unloosably fitted to the Bracket and the Clamp.

5.3.6 Suspension Clamp of SA

5.3.6.1 Suspension Clamps are used for locking the messenger of the ABC bundle without damaging the insulation or allowing the messenger to become dismounted from the fitting.

5.3.6.2 The Suspension Clamp shall accommodate messenger wires from 25 to 95 sq.m.

5.3.6.3 The Suspension Clamp shall be made fully of insulating type of mechanically strong and weather resistant plastic.

5.3.6.4 Bolts should not be used for clamping / locking the messenger in the Clamp.

5.3.6.5 There shall be no losable parts in the Suspension clamp.

5.3.6.6 The Suspension Clamp should be unloosably fitted to the rest of the Suspension Assembly.

5.3.7 Mechanical Test on Clamp of SA

5.3.7.1 The Sub Assembly shall be subjected to a vertical load applied as per drawing in accordance with Table-10. There shall be no breakdown or permanent deformation at load T initial for 1 minute or when the load is increased to T final and released.

Table - 10			
Conductor Size		T start (I minute)	T final (I minute)

TECHNICAL SPECIFICATION

Sq. mm.	Dia. (mm)	Rating (Kg.)	(Newtons)	(Newtons)
25-54	8-15	1500 Kg.	9,600	12,000
70-95	13-17	2000 Kg.	12,800	16,000

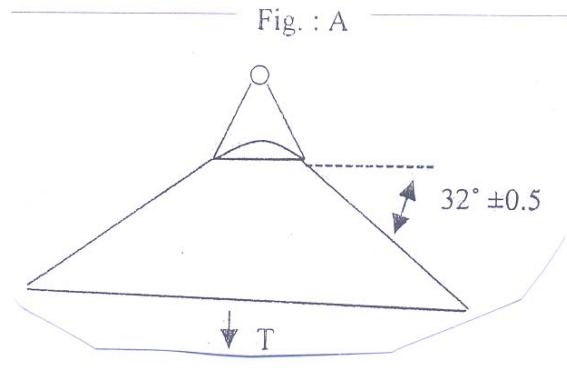

5.3.7.2 A sample messenger shall be fitted into a fixed suspension clamp and subjected to a gradually applied longitudinal load of 300 N. There shall be no permanent slippage.

5.3.8 Voltage Test of SA

A copper foil is wrapped at the clamping point around the maximum size of messenger allowed in that clamp. An ac voltage of 6 KV is applied between the copper foil and nearest conductive point of the clamp or into its absence to the point of fixation. The voltage should be withstood for 1 minute without breakdown or flashover.

5.3.9 Test Under Mechanical & Thermal Stress

5.3.9.1 The test specimen is made up of approx. 10mts. Of messenger wire strung between two anchor clamps with a Suspension Clamp fixed in the middle. Masses of 40 Kg. are suspended at a distance of 1-2mtr. On either side of the Suspension Clamp with a fixing mechanism of mass 2 ± 1 Kg.

5.3.9.2 The specimen is subjected to 500 cycles of 90 minutes each. Each cycle consists of the following :

	TECHNICAL SPECIFICATION	
--	--------------------------------	--

- a) For first 75 minutes a constant longitudinal tension of 4000 N is applied to the messenger for rating of 1500 Kg. and of 4500 N rating of 2000 Kg. while 64 cycles right and left oscillation are produced on the clamp 32° on either side of the vertical.
- b) During the first 45 minutes an intermittent current of 4-5 A/sq.mm is applied to maintain the conductor temp at $60 \pm 3^{\circ}$ C.
- c) During the next 45 minutes of the cycle the conductor is allowed to cool down naturally to the ambient.
- d) At the 75th minute, after having completed 64 oscillations, the oscillations are stopped and the longitudinal tension is increased to 7500 N for 1500 kg. Rating and 10000 N for 2000 Kg. Rating.

3.9.3 No messenger slippage should occur within the Suspension Clamp during the 500 cycles.

5.3.9.4 At the end of the 500 cycles, the messenger is immersed in water for 30 minutes. It is then tested to withstand 10 kV ac for 1 minute with a trip setting of 10 ± 0.5 mA. There should be no breakdown or flashover.

5.4 **Acceptance Tests**

5.4.1 The following shall constitute Acceptance Tests for Insulation Piercing Connectors (IPC) :

- λ Visual *
- λ Dimensional (as per SCD and overall dimensions submitted with Tender Offer)*
- λ Electrical Ageing Test ***
- λ Dielectric and Water Tightness Test. **
- λ Mechanical Tightening Test **
- λ Effect of Tightening on Main Core **
- λ Effect of Tightening on Branch Core **

	TECHNICAL SPECIFICATION	
--	--------------------------------	--

The above tests are to be carried out as per sampling plan below. However electrical ageing test on IPC (market***) is to be done on only one connector of each type and size.

In case of random failure/defect, double the sample lot is to be drawn and there should be no failure/defect exceeding half the permissible defects (rounded down) shown in the chart.

Lot Size	For tests Marked*		For Tests Market **	
	Sample Size	Max. permissible Defects	Sample Size	Max. permissible Defects
Upto 100	2	nil	2	nil
101 to 1000	6	nil	4	nil
>1001	0.01% subject to min. 6 pieces	0.1% of pieces checked	4	nil

5.4.2 The following shall constitute acceptance tests for Anchor Assemblies :

- λ Visual *
- λ Dimensional (as per SCD and overall dimensions submitted with Tender Offer)*
- λ Mechanical Test on Bracket**
- λ Mechanical Test on Clamp **
- λ Voltage Test *

5.4.3 The following shall constitute acceptance tests for Suspension Assemblies :

- λ Visual *
- λ Dimensional (as per SCD and overall dimensions submitted with Tender Offer)*
- λ Mechanical Test on Bracket**
- λ Mechanical Test on Clamp **
- λ Voltage Test *

	TECHNICAL SPECIFICATION	
--	--------------------------------	--

The above tests (for AA & SA) are to be carried out as per sampling plan below. In case of random failure/defect, double the sample lot is to be drawn and there should be no failure/defect exceeding half the permissible defects (rounded down) shown in the chart.

Lot Size	For tests Marked*		For Tests Market **	
	Sample Size	Max. permissible Defects	Sample Size	Max. permissible Defects
Upto 100	2	nil	1	nil
101 - 500	5	1	2	nil
501 - 2500	10	2	2	nil
2501 & above	10 + 0.2 %	2 + 10% pf addl. Sample quantity	4	1

6.0 SERVICE CLAMP

The clamps should be designed to anchor insulated service lines (armoured or unarmoured) with 2/4 conductors.

- λ The clamps should be made of weather and UV resistant polymer.
- λ No losable part in the process of clamping arrangement
- λ The clamp should conform to the standard NFC 33042 or equivalent I.S., if any. No losable
- λ Breaking Load of the clamp should not be less than 3 KN.

7.0 TRANSFORMER CONNECTION

- λ The connection to the transformer should be made with Pre-Insulated lugs for phase and street lighting conductors and with an Aluminium Lug for neutral Messenger. If the Bus-bars-bars are of copper, the Lugs should be preferably Bi-metallic type.
- λ The Barrel of the lug normally insulated with an Anti-UV black Thermoplastic tube sealed with a flexible ring. Die reference, size and strip length are to be indicated on the plastic.
- λ Sizes covered 16-70 & upto 150 m² Aluminium XLPE insulated cable.
- λ Reference standard NFC 33021 or equivalent I.S. if any.

	TECHNICAL SPECIFICATION	
--	--------------------------------	--

8.0 **JUNCTION SLEEVES**

- λ The sleeves should be Pre-Insulated for phases, neutral messengers and street lighting conductors.
- λ Sleeve should be made of Alluminium, insulated with an Anti-UV black thermoplastic tube hermetically sealed two ends with 2 flexible rings.
- λ Die reference, size and strip length are indicated on the sleeve itself.
- λ Sizes needed : 16-70 & upto 150 mm² for Alluminium XLPE insulated cable.
- λ Reference standard : NFC 33021 or equivalent I.S. if any.
- λ Design as per furnished drawing.

9.0 **EYE HOOKS**

- λ Eye looks should be designed as to hold suspension clamps and Dead end clamps and to be installed with the pole clamp.
- λ Eye-hooks should be made of forged Galvanised steel.
- λ The clamps corrosion resistance should conform the standards I.S. 2629 & I.S. 2633.
- λ Bolts and nuts should be made of hot dip Galvanised steel according to VDE 0210 and VDE 0212.
- λ Ultimate Tensile strength (UTs) of the clamp should 20 KN.
- λ Design as per furnished drawing.

10.0 **SERVICE MAIN DISTRIBUTION BOXES**

10.1 **Scope**

	TECHNICAL SPECIFICATION	
--	--------------------------------	--

This Distribution Box should be Weather & Moisture Proof with Spring loaded/Bolt & Nut type Bus Bar system & should be able to carry a current according to specified capacity. It can have 1/3-phase input & provision of 4 to 6 nos. of 3-phase or 1-phase outputs. The box should have the provision for special key for locking & Proper arrangement of sealing. The boxes should be assembled on the pole using Metal Tapes & Buckles or Bolts. No. of Boxes per pole may vary with supporting arrangement for more no. of service connections. The Spring used should be of stainless steel having required capacity to provide suitable pressure in the connector.

10.2 **Construction**

Distribution Boxes should be designed with Bus Bars with spring action contact, or screw-bolt technique. For spring action contact only insertion of the conductor into the specified groove of the Busbar is sufficient for proper connection whereas for Nut Bolt type proper washers & other accessories are to be provided for connections. It should be used for multiple connections (3-phase or 1-phase) in low voltage Distribution Network. The boxes should be suitable for 1/3-phase (4 crores) inputs & provision for 4 to 6 nos. of 3-phase or 1-phase outputs. Bus bars should be with a continuous pair of contact bars with colour code to facilitate the identification of the correct energy phase.

The box should be able to incorporate the input or output cable dia. Of maximum 16mm. (Equivalent to 120Sq.mm.).

The Boxes should consist of special type Lock & key system as well as provision for sealing for complete protection of the service connection contacts.

10.3 **Current Ratings**

The maximum current rating should be 140A/200A/250A & concerned authority should have the liberty to choose among the above ratings as per their requirement.

10.4 **Voltage Ratings :**

The maximum voltage withstand capacity should be 600V.

Working Temp

	TECHNICAL SPECIFICATION	
--	--------------------------------	--

Safe working temperature should be around 80 C for Outer Box & 100⁰C for metallic Bus bars.

10.5 Materials

Material used in the manufacturing process of the components of this product should be specified in the respective product drawings & can be summarized as follows :

- λ Outer Box (Base & Cap) : With UV protection & Flame retardant characteristics (HB, as per UL 94-Tests for Flammability of Plastic materials) & preferably made up of ASA (Achylnitrile Styrene Acrylate).
- λ Cable Grommets : Ethylene-Propylene Rubber :
- λ Safety Key : PA 6.6 (Nylon).
- λ Safety Screw : Stainless Steel or Plating Finished steel.
- λ Insulation protection as per IP 44.
- λ Bus bars or Terminal Blocks : PA 6.6 (Nylon), Stainless Steel & Copper.
- λ Button & Cable Holder : PA 6.6 (Nylon) with 50% Glass Fibre.
- λ Busbar Insulation : Polyimide.

10.6 Locking System

The boxes should consist of Special type Lock & Key arrangement as well as provision for sealing for complete protection of the service connection contacts.

11.0 G.A. DRAWINGS ETC.

- 11.1 A drawing / picture clearly showing principal parts & dimensions for all products should be submitted along with the offer.
- 11.2 The principal outer dimensions of each item, 1 x b x w in mm and weight in gms should be submitted along with the offer.
- 11.3 The Purchaser may call for samples for verification & evaluation purposes.

12.0 GENERAL CONDITIONS OF MANUFACTURE – Annexure – 2

13.0 GTP

	TECHNICAL SPECIFICATION	
--	--------------------------------	--

The Guaranteed Technical Particulars should be filled up in the given format of GTP.-
Annexure-3 to 7.

14.0 TESTING STANDARD – Given in Annexure 8 to 9.

ANNEXURE – 1

METEOROLOGICAL DETAILS

Sl. No.	Parameters	Unit	Value
1	Maximum ambient air temperature	°C	50
2	Maximum temperature of air in shade	°C	50
3	Maximum temperature of air in Sun	°C	60
4	Maximum daily average temperature	°C	45
5	Maximum yearly average temperature	°C	30
6	Maximum yearly weighted average temperature	°C	32
7	Minimum ambient air temperature	°C	4
8	Minimum temperature of air in shade	°C	4
9	Maximum relative Humidity	%	100
10	Average annual Rainfall	mm	3175
11	No. of months of tropical monsoon	No.	5 (June-Oct.)
12	Average no. of rainy days per annum	No.	80
13	Maximum wind pressure	Kg/m ²	100
14	Number of Dust Storms	Days/annum	5
15.	Average no. of stormy rainfall (exceeding 30 minutes in 24 hrs.)	Days/annum	10
16	Average number of thunderstorms	Days/annum	100
17	Earthquake acceleration	Mtr./sec ²	0.04x2 g.

TECHNICAL SPECIFICATION		
--------------------------------	--	--

18	Seismic Zone as per IS : 1893 – 1984	-	III & IV
19	Maximum height above mean sea level	Mtrs.	1000

- Note :
- 1) Any specific meteorological data other than those listed above applicable for a particular equipment/item will be available in the technical specification for that equipment/item.
 - 2) When values specified above contradicts with respective equipment TS, the later will prevail for that equipment.
 - 3) The atmosphere in the area is laden with industrial and town gases and smoke with dust in suspension during the dry months and subject to tough colder months.
 - 4) Heavy lightning is usual in the area during the months from May to November.

	TECHNICAL SPECIFICATION	
--	--------------------------------	--

ANNEXURE-2

GENERAL CONDITIONS FOR MANUFACTURE

The products shall be in accordance recognized standards used in L.T. ABC or equivalent I.S., if any.

- λ **Marking** : Each product shall be clearly identified with manufacturer name or trade mark, reference and capacity of the item and batch no.
- λ **Packaging** : Manufacturer shall mention the packaging of each item. Installation instruction should be included in packaging.
- λ **Type test** : Each supplier should provide type test reports with the offer, carried out in accordance with one of the reference standards in NABL Accredited Laboratory.
- λ **Routine test** : Supplier shall provide a control plan, which will be implemented on each item. Routine test reports should be submitted by the manufacturer with inspection call.
- λ **Quality** : All suppliers should preferably be ISO-9000 certified.
- λ Anchoring and suspension clamps should be installable on existing poles using appropriate devices (hooks, pigtails, brackets etc.).
- λ All crimped connectors should be installed with mechanical or hydraulic hand crimping tools.

	TECHNICAL SPECIFICATION	
--	--------------------------------	--

ANNEXURE – 3

GUARANTEED TECHNICAL PARTICULARS FOR ANCHOR CLAMPS
SUITABLE FOR INSULATED SERVICE LINE CABLE

Sl. No.	Parameters	Unit	Bidder's Offer
1	Type of Clamp		
2	Name of the Manufacturer		
3	Standard		
4	Place of Manufacturer		
5	Range of conductor size	mm. (Dia.)	
6	Type of design		
7	Installation (with / without disassembly)		
8	Type & grade Metallic / Nonmetallic material		
9	Marking		
10	Colour of Nonmetallic parts		
11	Dimensions	Mm	
12	Approximate weight	Kg	
13	Breaking Load	KN	

	TECHNICAL SPECIFICATION	
--	--------------------------------	--

ANNEXURE – 4

GUARANTEED TECHNICAL PARTICULARS FOR EYE HOOK (FLAT TYPE)

Sl. No.	Parameters	Unit	Bidder's Offer
1	Type of Clamp		
2	Name of the Manufacturer		
3	Place of Manufacturer		
4	Type of design		
5	Type & grade Metallic / Nonmetallic material		
6	Type of hot dip galvanizing & thickness of Zinc coating		
7	Dimensions	Mm	
8	Approximate weight	Kg	
13	Ultimate tensile strength	KN	

	TECHNICAL SPECIFICATION	
--	--------------------------------	--

ANNEXURE – 5

**GUARANTEED TECHNICAL PARTICULARS FOR WATERPROOF
PREINSULATED COMPRESSION TYPE BIMETALLIC SOCKET FOR LT 1.1KV**

1.	Name & address of the Manufacturer	
2.	Applicable standard	
3.	Type of Cable jointing kit	
4.	Application	
5.	Nominal system voltage (kV)	
6.	Maximum system voltage (kV)	
7.	Number of cores	
8.	Type of Insulation	
9.	Type of screening	
10.	System Neutral Earthing	
11.	Maximum performance	
12.	AC voltage	
13.	Load cycling 90 ⁰ C + 5 ⁰ C (no. of cycles)	
14.	Impulse voltage	
15.	Partial discharge voltage	
16.	Thermal short circuit	
17.	DC voltage	
18.	Dynamic short circuit	

	TECHNICAL SPECIFICATION	
--	--------------------------------	--

ANNEXURE – 6

**GUARANTEED TECHNICAL PARTICULARS FOR
PREMOULDED STRAIGHT JOINT FOR LT 1.1 KV**

1.	Name & address of the Manufacturer	
2.	Applicable standard	
3.	Type of Cable jointing kit	
4.	Application	
5.	Nominal system voltage (kV)	
6.	Maximum system voltage (kV)	
7.	Number of cores	
8.	Type of Insulation	
9.	Type of screening	
10.	System Neutral Earthling	
11.	Maximum performance	
12.	AC voltage	
13.	Load cycling 90 ⁰ C + 5 ⁰ C (no. of cycles)	
14.	Impulse voltage	
15.	Partial discharge voltage	
16.	Thermal short circuit	
17.	DC voltage	
18.	Dynamic short circuit	

	TECHNICAL SPECIFICATION	
--	--------------------------------	--

ANNEXURE – 7

**GUARANTEED TECHNICAL PARTICULARS FOR
INSULATING PIERCING CONNECTORS**

		For Street Light	For DB Charging	For ABC to ABC TEE
1.	Name of the Manufacturer			
2.	Is Manufacturer of accessories as ISO 9001-2000 company a) Copies of certificate enclosed b) Are GA Drawing enclosed			
3.	Applicable			
4.	Applicable standard			
5.	Type of connectors	Main : 16-95sqmm Tap : 1.5-10 sqmm	Main: 16-95sqmm Tap : 4-35 sqmm	Main: 25-95sqmm Tap : 25-95 sqmm
6.	Application	For 1.1 KV	For 1.1 KV	For 1.1 KV
7.	Is any metallic part carrying potential in operation exposed during installation			
8.	Are end caps of branch cable a) Slide on type b) Rigid			
9.	Are torque limiting shear heads provided to tightening bolts			

TECHNICAL SPECIFICATION

10.	Range of cable sizes accommodated for main & branch	Main : 16-95 sqmm Tap : 1.5-10 sq.mm	Main: 16-95sqmm Tap: 4-35sqmm	Main: 25-95sqmm Tap: 25-95sqmm
11.	Min. & Max. torque defined			
12.	Torque for establishing connection between main and branch			
		For Street Light	For DB Charging	For ABC to ABC TEE
13.	Max. tensile load for no breakdown of main conductor (for each cross section)			
14.	Max. tensile load on branch conductor for no break/slippage			
15.	Voltage withstand under water emersion			
16.	Is electrical Ageing test report enclosed			
17.	No. of Cycles			
18.	Max. temp. at each cycle			
19.	Marking and embossing on the connection			

	TECHNICAL SPECIFICATION	
--	--------------------------------	--

ANNEXURE – 8

TESTING STANDARDS :

The Insulating Piercing Connector should conform to following std. :

Tests	Tests Standard / Test Procedure
Corrosion Qualification Test	<p>As per NF C 33-020 (Jun '98), or equivalent I.S., if any.</p> <p>Exposure in Saline Environment : The exposure should be carried out as per NF en 60068-2-11 (Aug. '99) std. requirement. The concentration of Saline solution must be of 5% \pm 1% in mass, & the temperature of the test chamber must be maintained at 35°C \pm 2°C.</p> <p>Exposure in Sulphur environment saturated of humidity – The exposure should be carried out as per NF T 30-055 (Mar. '74) std. requirement. SO₂ concentration in the chamber should be 0.067% in volume. The temperature of the test chamber should be increased to 40°C \pm 3°C.</p> <p>The total test should include four identical periods of 14 days, in which 7 days of exposure in Saline environment & in other 7 days – 8 hrs. cycles in SO₂ environment & 16 hrs. in laboratory environment.</p>
Electrical Ageing Test	<p>As per NF C 33-020 & NF C 33-004 (Jun '98) or equivalent I.S., if any.</p> <p>Total no. of cycles 200, Heating time -60 mins., Cooling time -45 mins., Pause time – 2 mins.</p>
Dielectric Investigation Test in	<p>As per NF C 33-020 (Jun '98) or equivalent I.S., if any.</p> <p>The connector should be placed in an ambient temperature between</p>

	TECHNICAL SPECIFICATION	
--	--------------------------------	--

Water	15°C & 30°C & relative humidity between 25% & 75%. The tightening of the connectors should be at minimal value of the torque indicated by the manufacturer. The sample should be placed in tank full of water on 30 cm height, after an immersion length of 30 mins. The set is subjected to a dielectric test under a voltage of 6 KV at industrial frequency during 1 min. No flashover / breakdown should occur at 6 KV during 1 min.
Tests	Tests Standard / Test Procedure
Mechanical Tests	As per NF C 33-020 (Jun '98) or equivalent I.S., if any. For checking electrical continuity, shear heads & mechanical behaviour of the connector's suitable tests as per the above specification have to conduct.

Capacity needed :

For ABC 16 to 95 mm²

Model 1 for customer service

Main 16 to 95 mm²

Tap 2.5 to 10 mm² (For Street lighting)

Design as per furnished drawing

Model 2 for customer service

Main 16 to 95 mm²

Tap 04 to 35 mm² (for distribution box charging)

Design as per furnished drawing

Model 3 for customer service

Main 25 to 95 mm²

Tap 25 to 95 mm² (For ABC to ABC Tee Joint)

Design as per furnished drawing.

TECHNICAL SPECIFICATION

ANNEXURE – 9

TESTING STANDARDS

Impact Resistance should be according to UL 746C. Insulation Protection should be as per IP 44.

The Quater Plastic box should conform to following std. -

Test / Standard	Requirements	Test Procedures
Degree of Protection IEC 60529	IP 44 – Protected against the penetration of solid objects exceeding 1.0mm in diameter and against penetration of water jets that may affect the product operation.	First Digit : A 1.0mm diameter test wire should not penetrate in any apparent opening (force = 1 N \pm 10%) Second Digit : A spray nozzle is used to spread a water jet in all possible directions.
Impact Resistance UL 746-C	After the test the product should not show any evidence of : - Live electrical parts accessible to the test probe, as described in this test specification. - Any results, which may affect the mechanical performance of the product. - Any results, which may increase the probability of electrical shocks.	The impact should be generated by dropping a steel ball – with a diameter of 50.8 mm and a mass of 0.535 kg – from a specified height sufficient to produce an impact energy of 6.8 J (0.69 13 kg.m.)
UV Resistance UL 746-C	The sample physical properties average value after an accelerated aging with UV radiation – should not be lower than 70% of its initial value,	According to ASTM G26, Exposure Method 1, Xenon Arc Lamp Type B or ASTM G 155, Exposure Cycle I, with continuous

TECHNICAL SPECIFICATION

	without aging, that is, a variation of + 30% is allowed.	exposure to light and intermittent exposure to water jets, with programmed cycles of 120 minutes, consisting of a 102 minutes light-only exposure and a 18 minutes exposure to light and water jets.
Withstanding Voltage UL 746-C	Product should withstand the specified voltage	A 5 kV voltage should be applied to the samples after the 40 hours conditioning cycle at $23 \pm 2^{\circ}\text{C}$ and $50 \pm 5\%$ relative humidity plus 96 hours at $35 \pm 2^{\circ}\text{C}$ and $90 \pm 5\%$ relative humidity.
Flammability UL 94	After the UV radiation accelerated aging, the material should maintain the same original flammability level (HB).	The test can be applied to test samples molded with the same material used for the base and the cap of the box or taking a piece of these components.
Flexural Strength ASTM D790 UL 746-C	After UV radiation accelerated aging, the average value for this test should not be lower than 70% of the original value, that is, a maximum variation of 30% is allowed.	A group of test samples without aging should be tested and the average values calculated. Another group should be aged under UV radiation then it should be tested and the new average should be calculated and compared to the initial average value.
Tensile Strength ASTM D638 UL 746-C	After aging with UV Radiation, the average value should not be lower than 70% of the initial values, that is, a maximum variation of 30% is allowed.	One of the test bodies must be tested without being submitted to accelerated aging and is computed over mean values. Another group is submitted to the radiation induced aging and then tested and the new mean value is computed and compared to the first computed mean value.

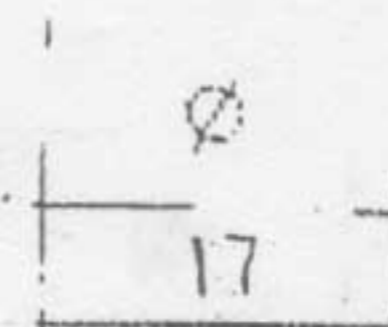
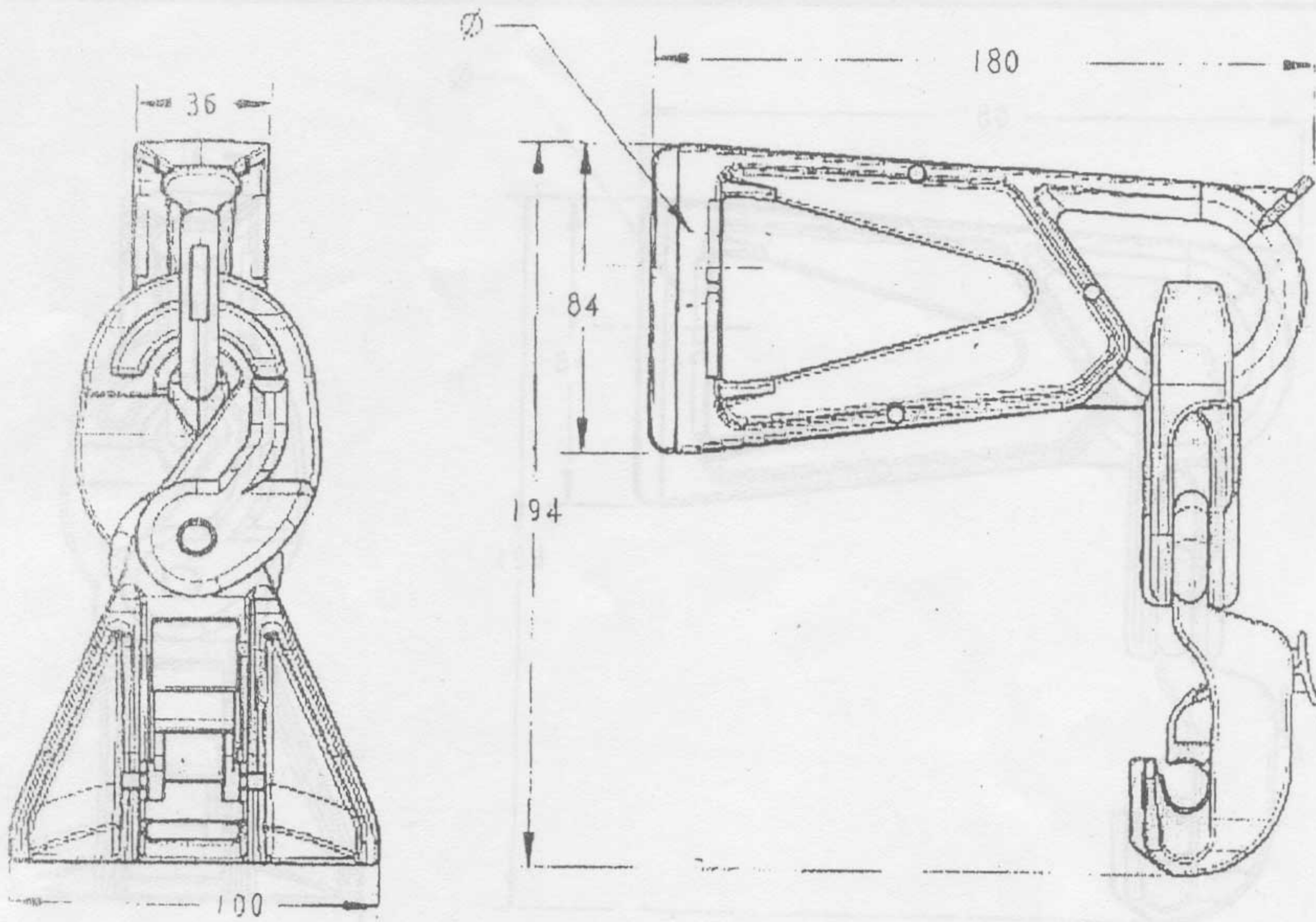

Standard : As per NF C 33040
UTS : 15KN
Maximum Allowable Load : 20KN
All Dimensions are in mm.
Not to Scale

W.B.S.E.D.C.L.
(A West Bengal Govt. Enterprise)
Name: Suspension Clamp
for 50/70 Sqmm. Insulated Messenger

ANNEXURE - B

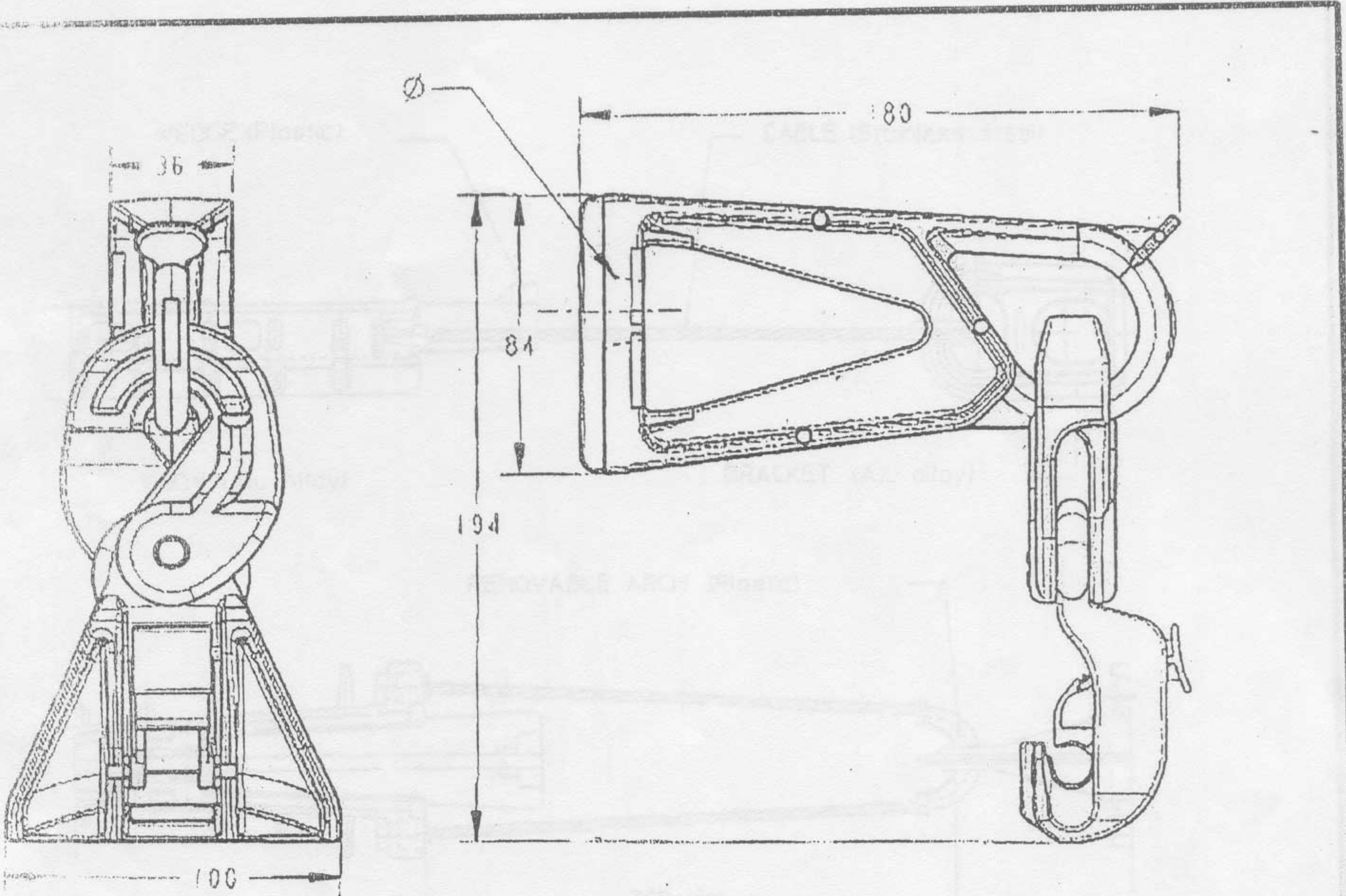

Ø
17

Standard : As per NF C 33040
UTS : 4.3KN
Maximum Allowable Load : 15KN
All Dimensions are in mm.
Not to Scale

W.B.S.E.D.C.L.

(A West Bengal Govt. Enterprise)

Name: Suspension Clamp

for 25/35 Sqmm. Insulated Messenger

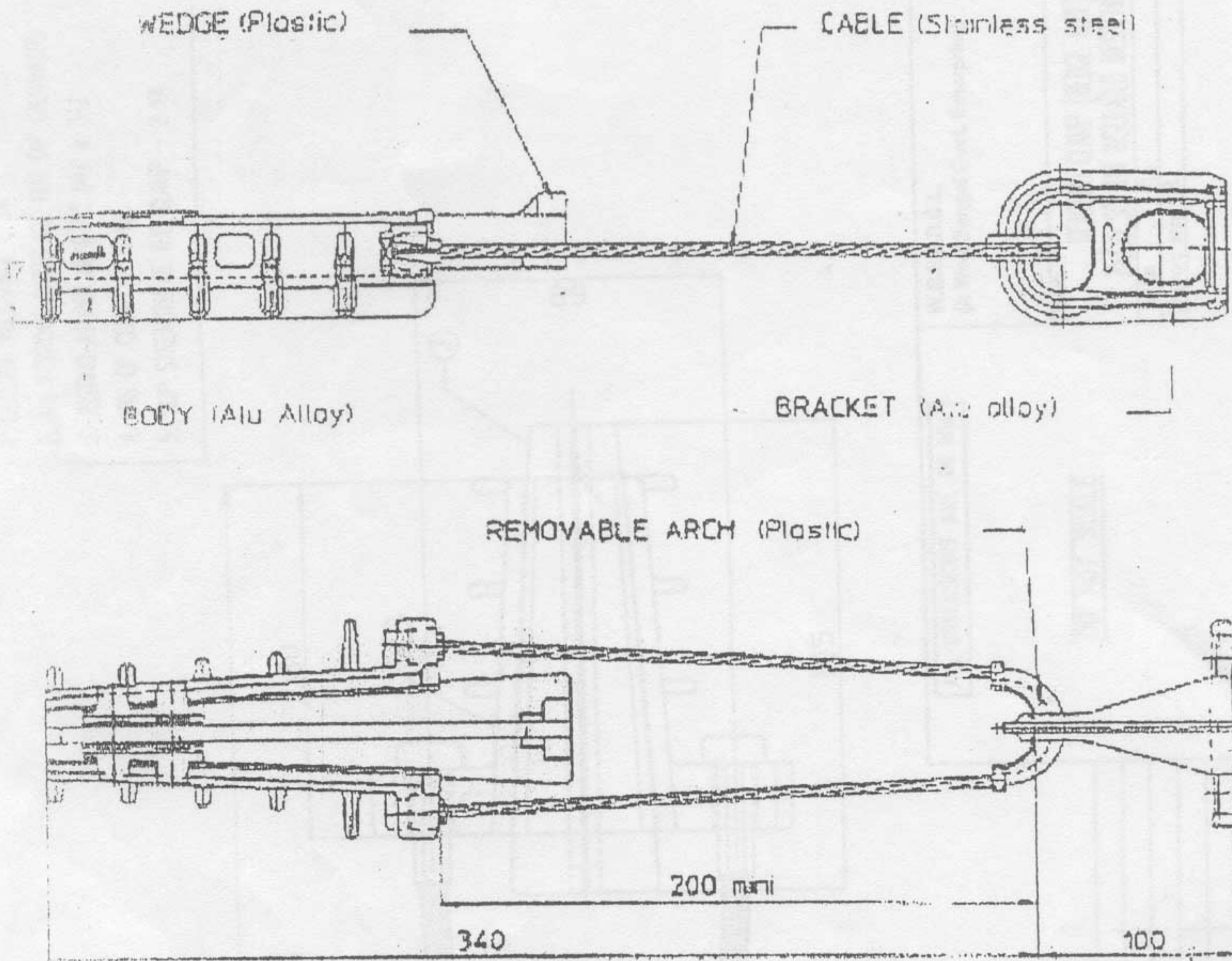

Standard : As per NF C 33041 & 042

Slip Load : 3KN

UTS : 15KN

All Dimensions are in mm.

Not to Scale

W.B.S.E.D.C.L.

(A West Bengal Govt. Enetrprise)

Name: Dead End Clamp

for 50/70 Sqmm. Insulated Messenger

TECHNICAL DATA

1. GENERAL TOLERANCE ± 3%
2. ALL FERROUS PARTS ARE HOT DIP GALVANIZED.
3. TESTING AS PER IEC C 33 041 & 042
4. UTS OF CLAMP - 10 KN
5. SLIP STRENGTH OF THE CLAMP - 2 KN.

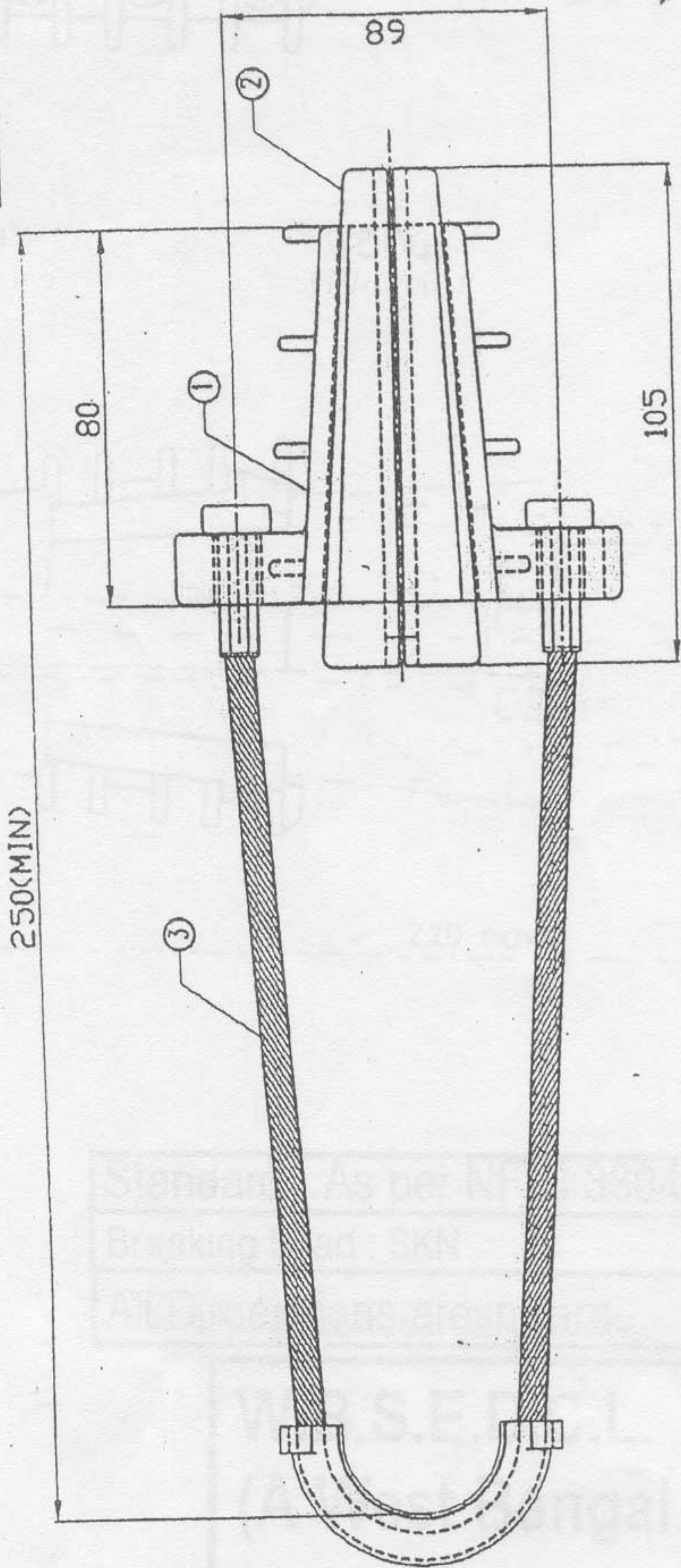

W.B.S.E.D.C.L.
(A West Bengal Govt. Enterprise)

TITLE: DEADEND CLAMP (WEDGE TYPE) FOR
25/35 SQ. MM INSULATED MESSENGER CABLE

SCALE: H/S
DRAWING SIZE: A

ALL DIMENSIONS ARE IN MM.

DO NOT SCALE

SL. NO.	DESCRIPTION	MATERIAL	QTY.	UTS.	DRC. NO.
3	STRAP	STEEL WIRE	1 NO		
2	WEDGES	WEATHER RESISTANT PLASTIC	1 SET		
1	CLAMP BODY	ALUMINIUM ALLOY, LM6	1 NO		

50

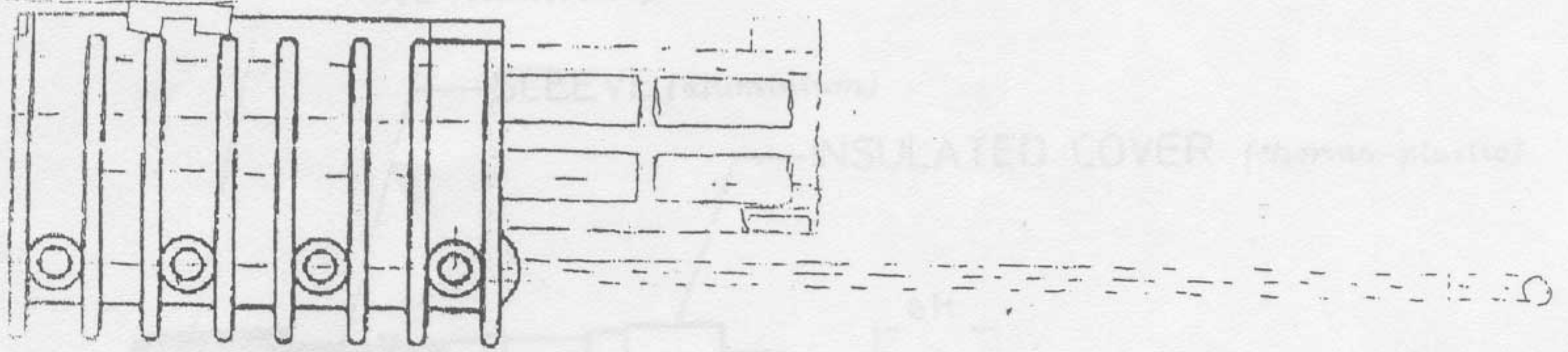

BODY
(Plastic)

WEDGE
(Plastic)

STIRRUP
(Stainless steel)

55

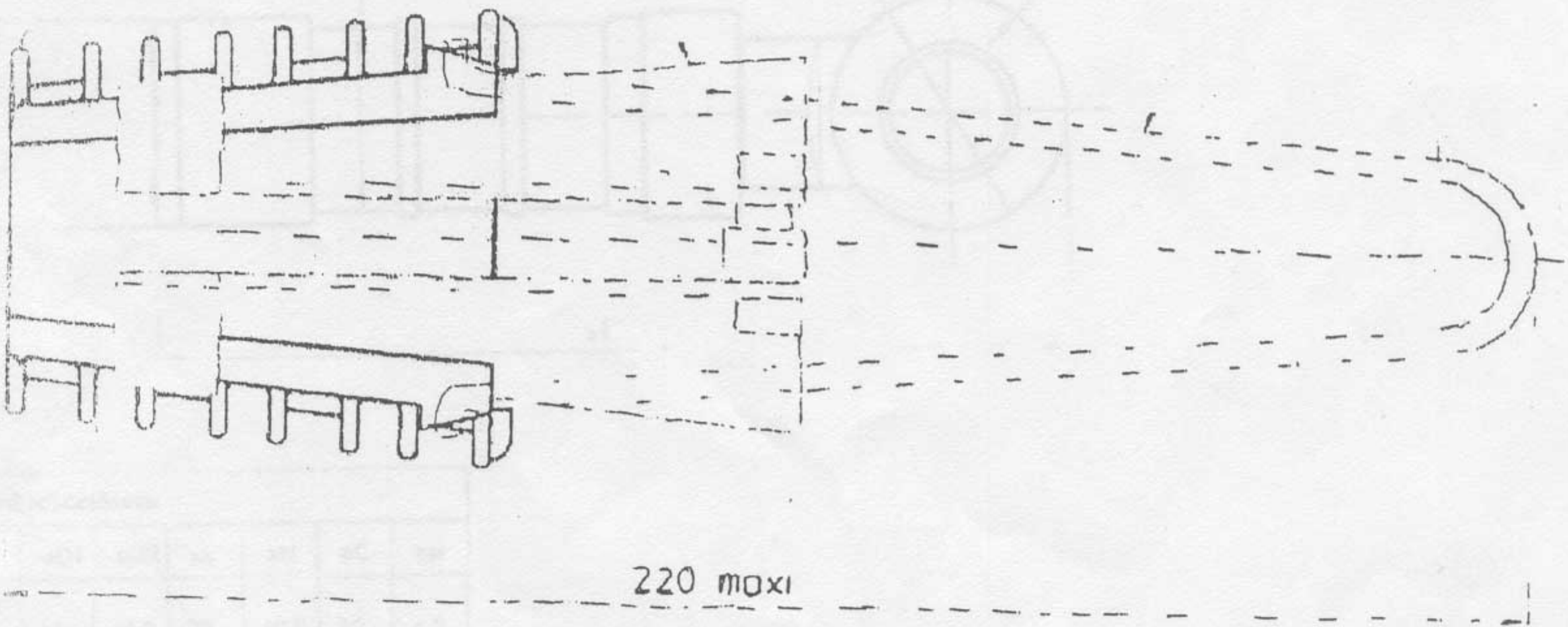

220 max

Standard : As per NF C 33042
 Breaking Load : 3KN
 All Dimensions are in mm.

Not to Scale

18 to 25 mm Insulated cable
 CAPACITIES : 1000 to 1500

W.B.S.E.D.C.L.
(A West Bengal Govt. Enterprise)

Name: Service Line Anchor Clamp

~~PRE-INSULATED TERMINAL LUGS~~

~~CPTAU~~

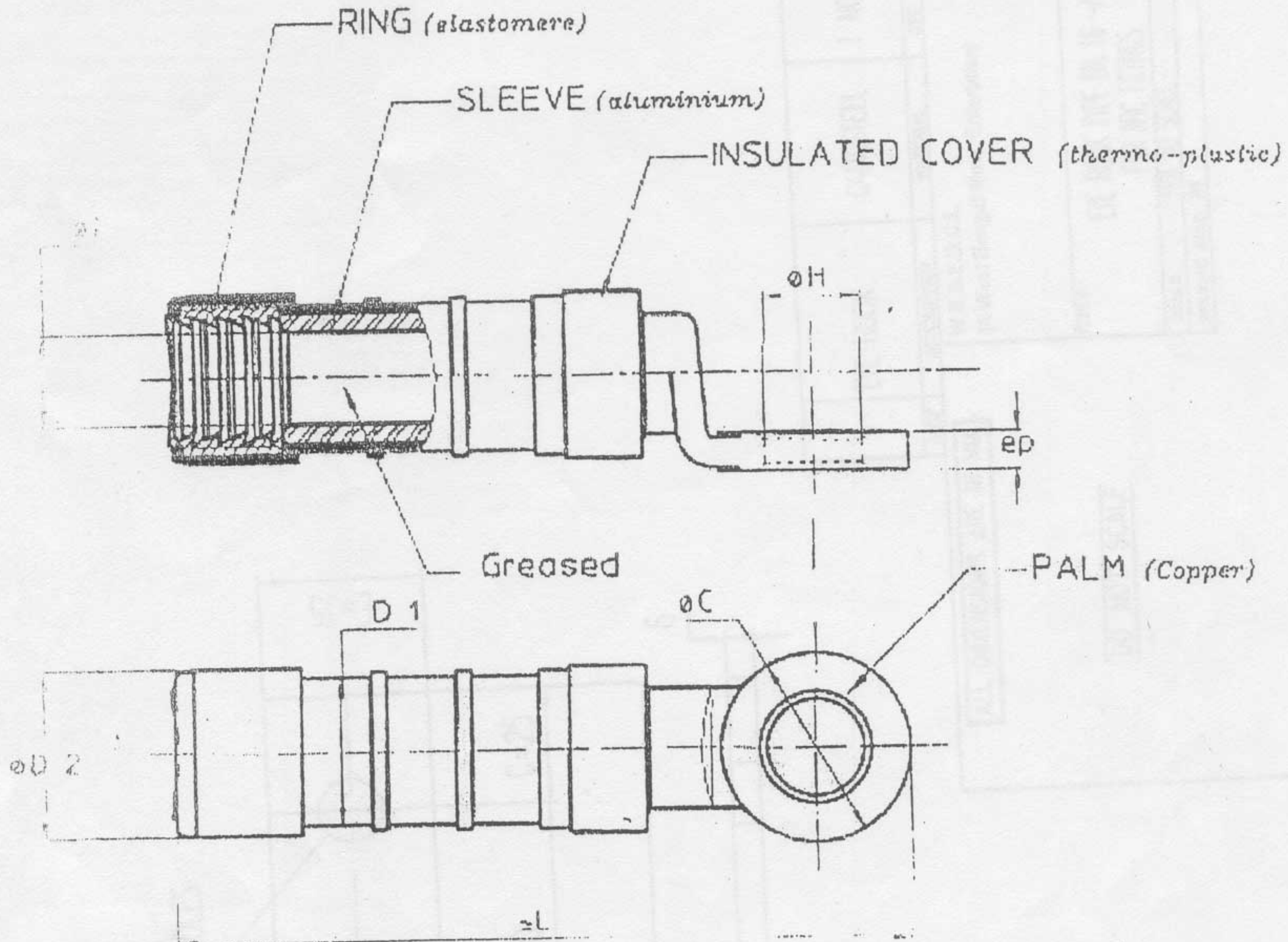
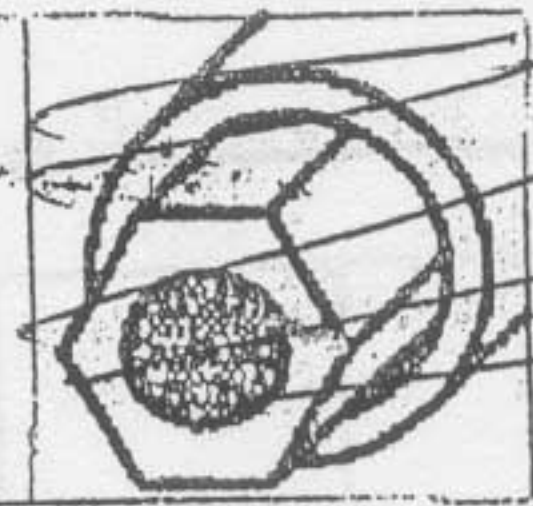

SECTION mm ²	DIMENSIONS (mm)						
	$\phi 1$	$\phi D 1$	$\phi D 2$	aL	aH	ϕC	ep
16	5.5	16	18.5	72	10.5	20	4.5
25	6.5						
35	7.5						
50	8.5						
75	9	20	22.5	99	12.8	25	5
100	10						
150	10.5						
200	12.2						
50 N	11.7	25	27	115	12.8	30	6
75	12.2				12.8		
120	14.2				12.8		
150	15.5				12.8		

Standard : As per NF C 33021

All Dimensions are in mm.

Not to Scale

W.B.S.E.D.C.L.

(A West Bengal Govt. Enterprise)

Name: Preinsulated Bimetallic

Socket. (For Transformer Connection)

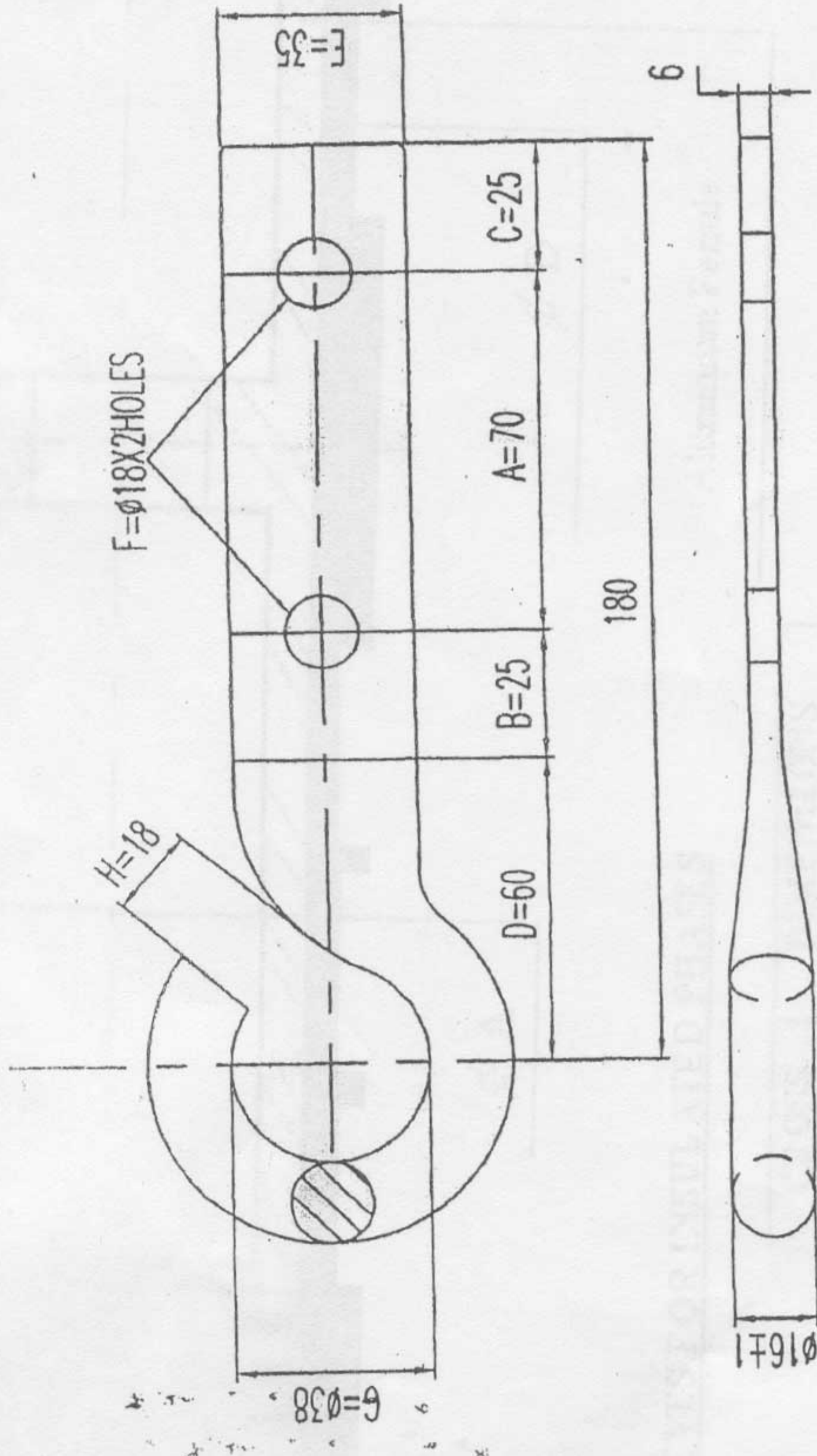

F=φ18X2HOLES

ALL DIMENSIONS ARE IN MM.

NOTES:

1. GENERAL TOLERANCE $\pm 15\%$.
2. EYE HOOK AS PER REC CONSTRUCTION STANDARD E-35.
3. FERROUS PARTS HOT DIP GALVANIZED AS PER IS: 2629.

DO NOT SCALE

ITEM	DESCRIPTION	MATERIAL	QTY	UTS NO.
1	EYE HOOK	GALV STEEL	1 NO	20

W.B.S.E.D.C.L.
(A West Bengal Govt. Enterprise)

TITLE: EYE HOOK TYPE DA 16 -A
FOR ABC FITTINGS

SCALE: NOT TO SCALE
DRAWING SIZE: A4

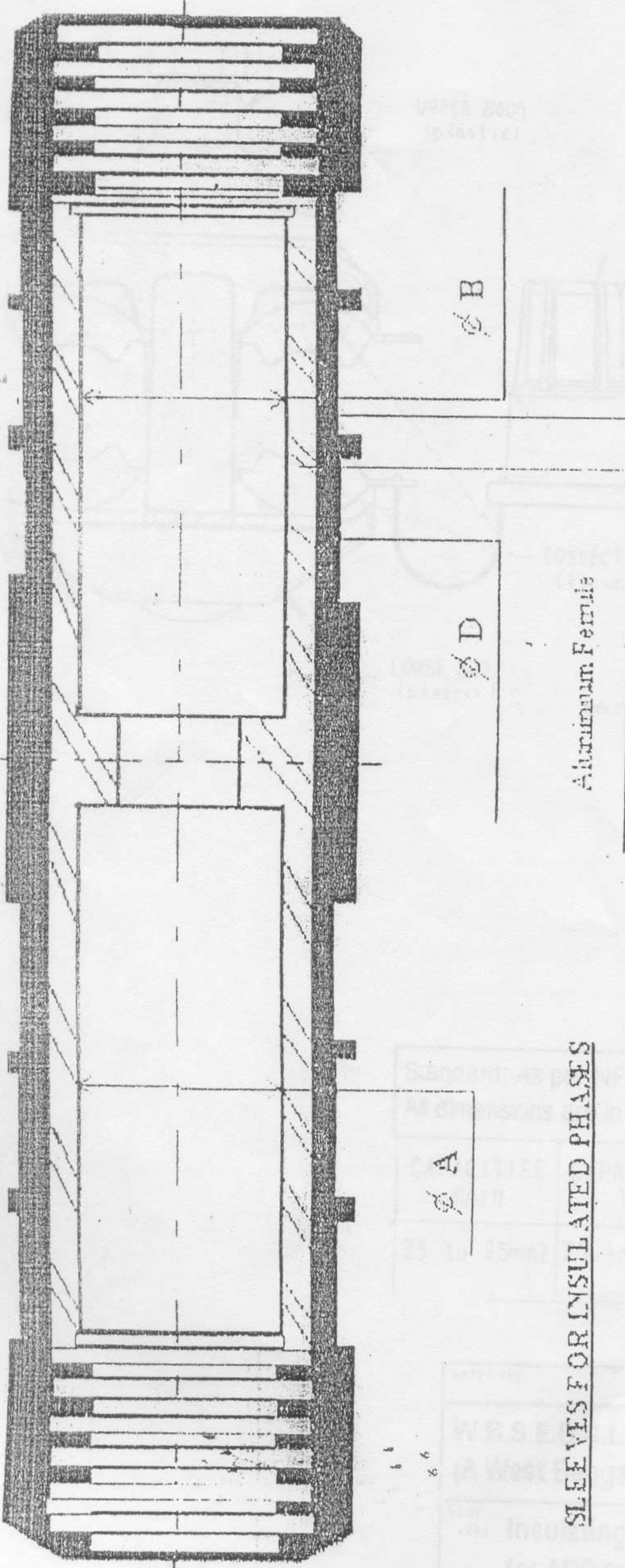

SLEEVES FOR INSULATED PHASES

CROSS SECTION (mm ²) MAIN	DIMENSIONS		
	ØA	ØB	ØD
16	55	55	20
25	65	65	20
35	8	8	20
50	9	9	20
70	105	105	20
95	122	122	20
120	142	142	25
150	155	155	25

W.B.S.E.D.C.L.

(A. West Bengal Govt. Enterprise)

**Pre Insulated
Waterproof Sleeves**

Standard: As per NF C33021

MARKING LOGO REFERENCE CAPACITIES DATE

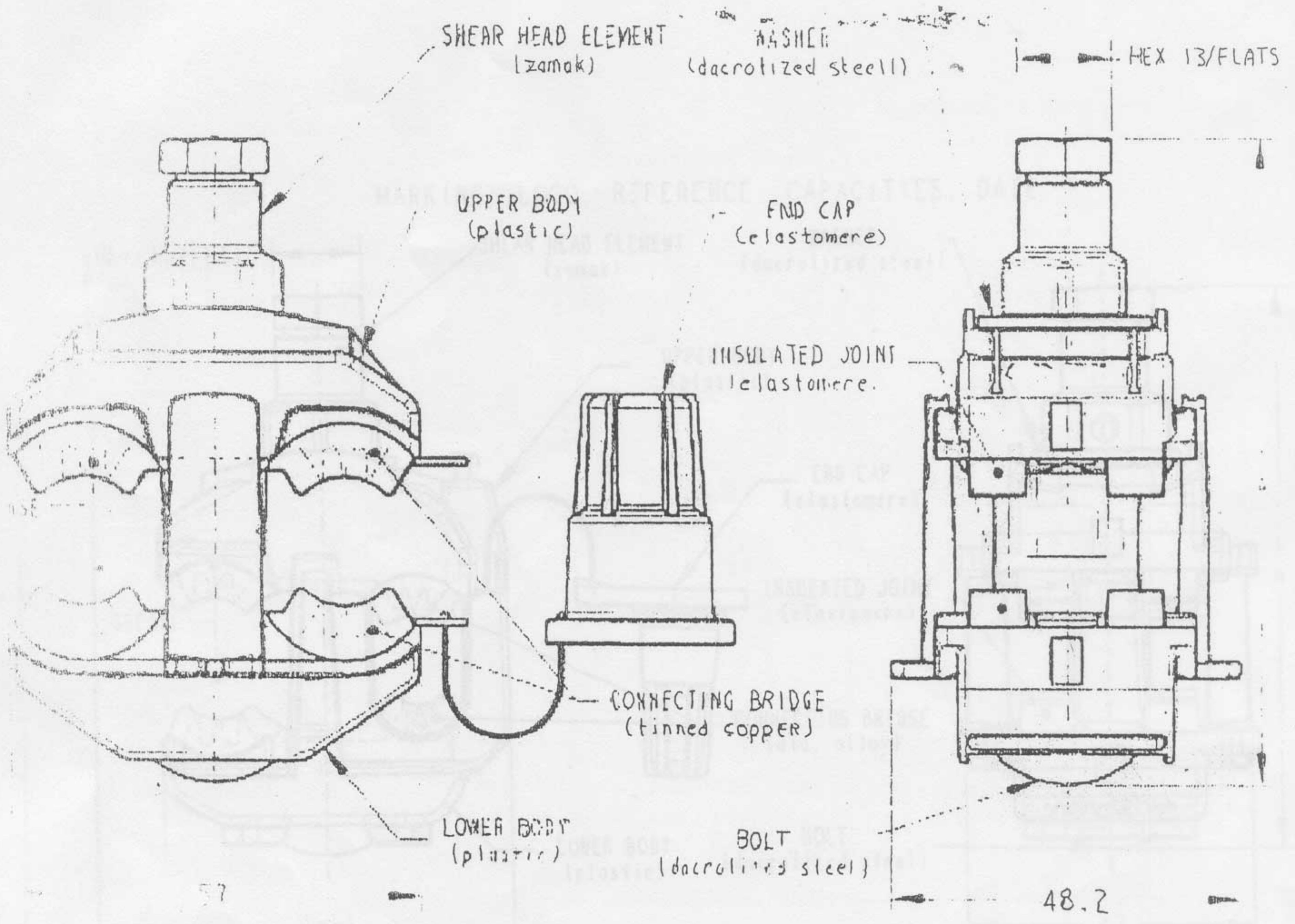

Standard: As per NF C 33020
All dimensions are in mm.

CAPACITIES MAIN	CAPACITIES TAP	WEIGHT	DIMENSION	BREAKING SHEAR HEAD TORQUE
25 to 95mm ²	25 to 95mm ²	137g	91mm	18Nm

TOLERANCES UNLESS OTHERWISE SPECIFIED
CENTRALS AND SPECIFICS

MATERIAL	IT A 50
W.B.S.E.D.C.L. (A West Bengal Govt. Enterprise)	
NAME	Insulating Piercing Connector for ABC to ABC Tee Joint

MARKING: LOGO, REFERENCE, CAPACITIES, DATE

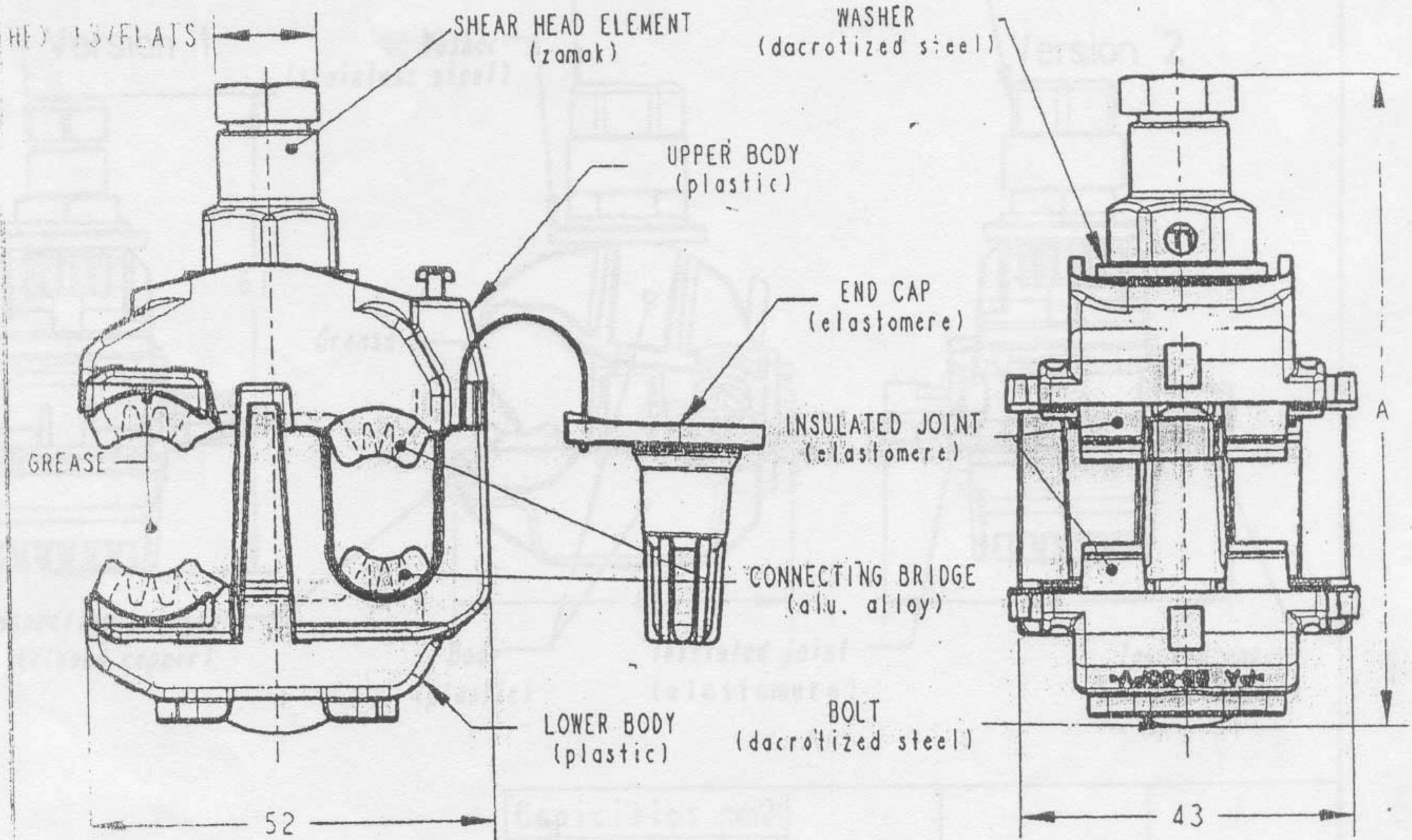

CAPACITIES MAIN	CAPACITIES TAP	WEIGHT	DIMENSION A	BREAKING SHEAR HEAD TORQUE
16 to 95mm ²	4 to 35mm ² (50mm ²)	113,5g	86mm	11Nm

Standard: As per NF C 33020
All dimension are in mm.

TOLERANCES UNLESS OTHERWISE SPECIFIED:
TOLERANCES NON-SPECIFIEES:

MATERIAL	-	FINISH	-
W.B.S.E.D.C.L. (A West Bengal Govt. Enterprise)			
NAME	Insulating Piercing Connector for Distribution Box Charging		

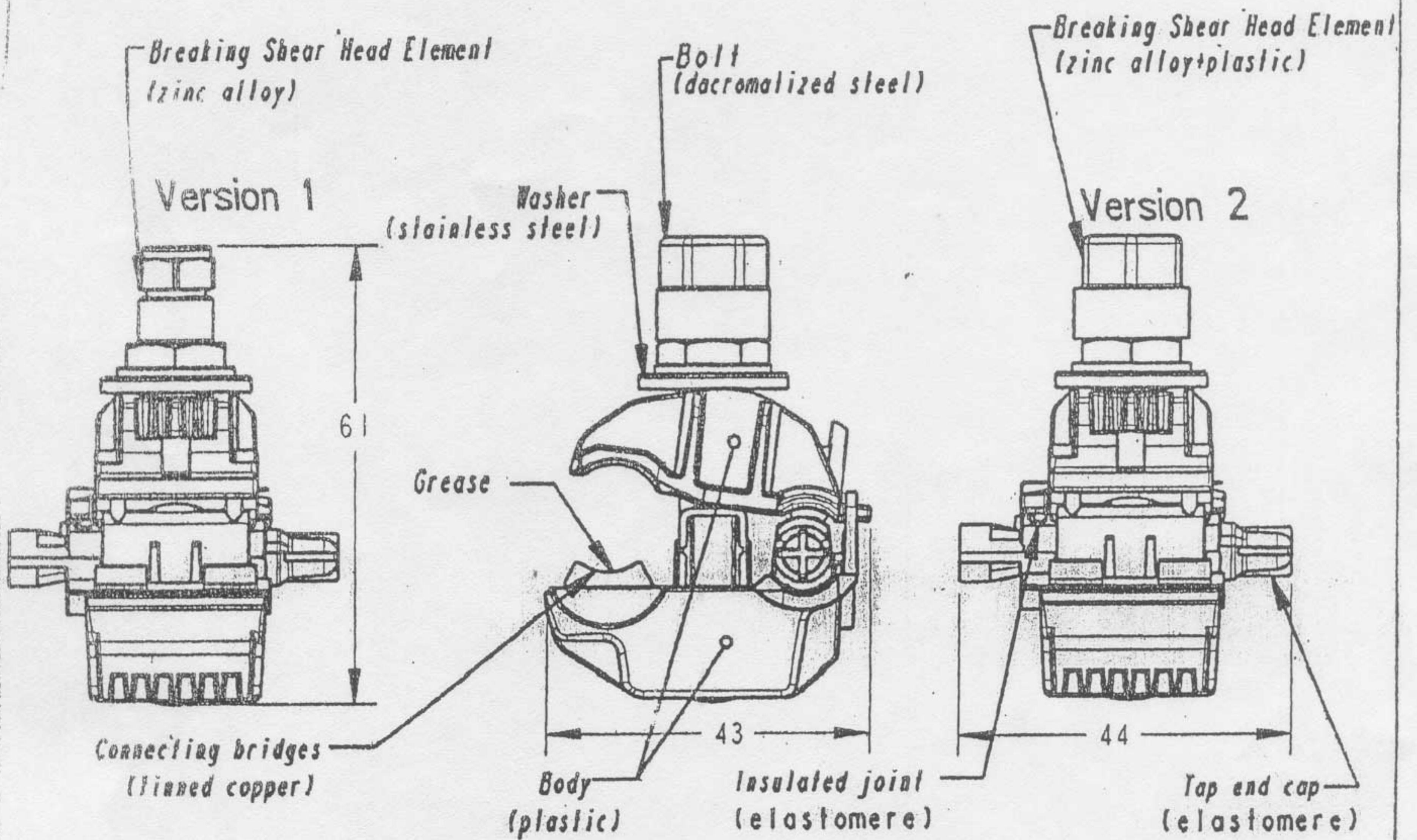

Capacities mm ²		Version	Breaking shear head torque	Hexagonal wrench
Main	Tap			
16-95	1,5-10	Version 1	6,8 to 8 Nm	10 mm

Standard: As per NF C 33020
All Dimensions are in mm.

TOLERANCES UNLESS OTHERWISE SPECIFIED:
TOLERANCES NOW SPECIFIED:

MATERIAL	FINISH
W.B.S.E.D.C.L. (A West Bengal Govt. Enterprise)	
NAME Insulating piercing Connector for Connection of Street Lights	